

# Reclaim Reels and Tanks

The Reclaim Reel is an integral part of Key's food pumping systems and removes primary waste from the water. A Reclaim Reel can be used as the reservoir for the pumping system. It is also used in other reclamation and reservoir applications, such as flume systems.

## Reclaim System Features

- Removes primary waste from recirculating water systems
- Three sizes available
- Stainless steel reels, 2 mm (1/16") perforations on 3 mm (1/8") centers (other sizes optional)
- Stainless steel tank and shafts
- Water level control
- 19 mm (3/4") NPT fresh water make-up inlet and valve
- 51 mm (2") NPT drain
- Optional distribution header
- Sanitary, easy-to-clean design

## Common Product Applications

- Fresh-cut
- Fruit
- Potatoes
- Root crops
- Squash
- Vegetables

*Other applications may be used on this equipment. Call Key to find out about how your product(s) may benefit from this technology or another system.*



*Reclaim Reel on a Strawberry Processing Line*

## Specifications

### Single Reel, Model 1501

- Capacity: 1,136 liters (300 gallons) per minute
- Reel diameter: 457 mm (18")
- Motor: 0.37 kW (1/2 hp), 230/460 volt, 50/60 Hz, 3 phase
- Stainless steel reel hood (option)
- Removable steel spirals (option)
- Stainless steel or aluminum butt plates

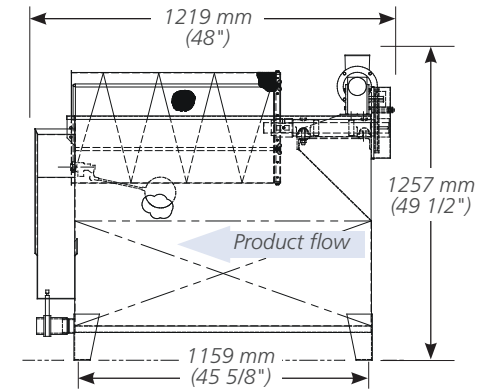
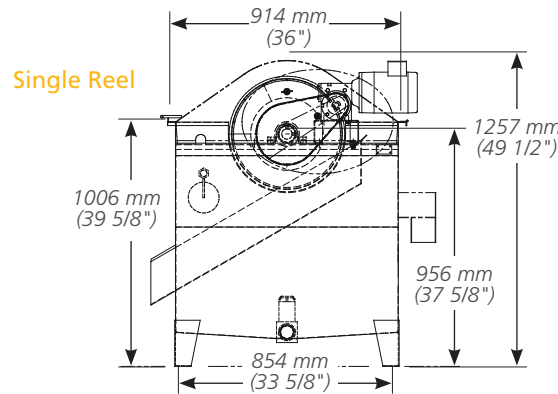

### Double Reel, Model 1504

- Capacity: 2,271 liters (600 gallons) per minute
- Reel diameter 457 mm (18")
- Motor 0.37 kW (1/2 hp), 230/460 volt, 50/60 Hz, 3 phase
- Stainless steel reel hood (option)
- Removable steel spirals (option)
- Stainless steel or aluminum butt plates

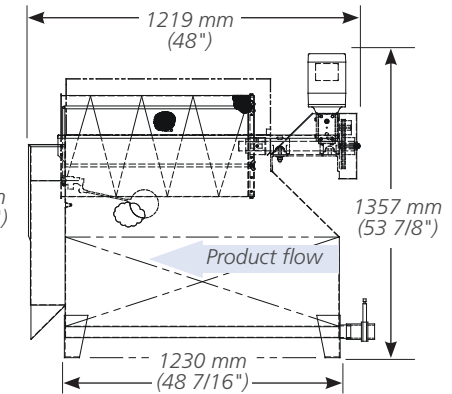
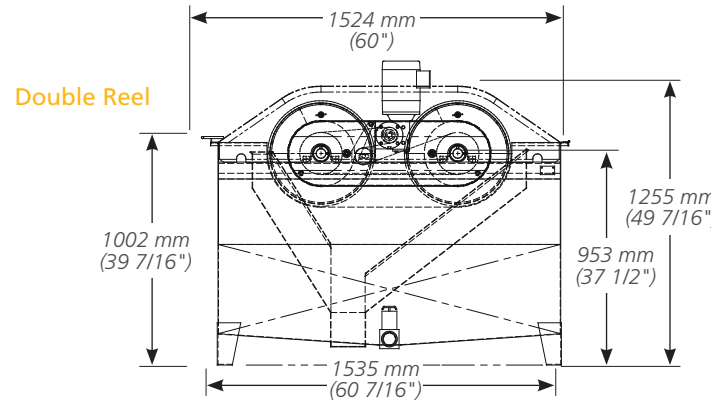

### Large Reel, Model 1510

- Capacity: 4,542 liters (1,200 gallons) per minute
- Reel diameter: 914 mm (36")
- Motor: 0.37 kW (1/2 hp), 230/460 volt, 50/60 Hz, 3 phase
- Stainless steel reel hood (option)

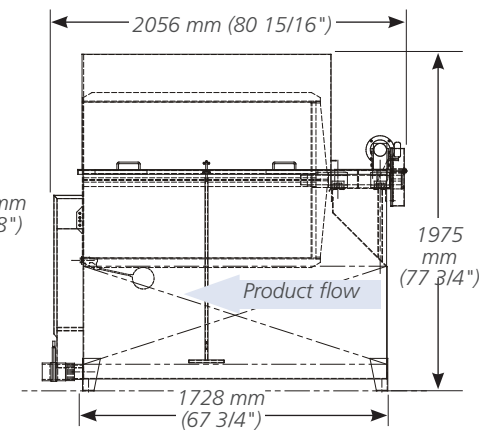
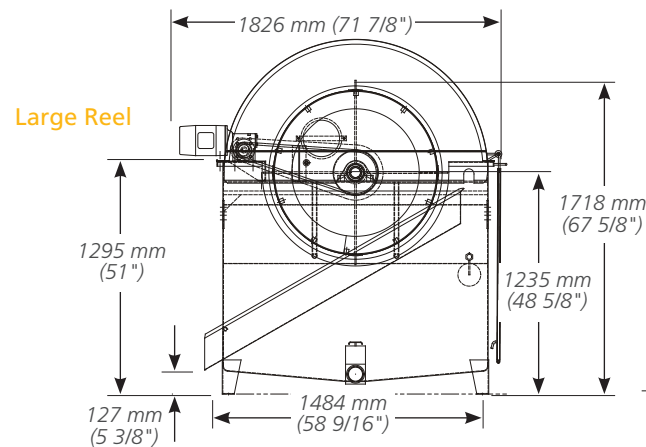

Note: Drawings are representative.  
Final configuration of equipment may vary by application.