

SYMETIX®

Automation for Capsule, Tablet & Softgel Integrity

Pulse Scrubber®

Continuous Softgel Polishing Systems

The industry's first continuous polishing system for softgel capsules, PulseScrubber™ automatically, and without solvents, removes mineral oil and leaked content from softgels. Designed for pharmaceutical and nutraceutical manufacturers, the system polishes capsules by removing excess oil used in the encapsulation process, to improve product presentation.

PulseScrubber conveys capsules via Impulse® electromagnetic conveying technology, while absorption media above and below gently polish the product surface via vibratory motion. PulseScrubber operates unattended and conveniently replaces traditional batch polishing systems that require manual loading and unloading.

- **Capacity** up to 1,000,000 softgels per hour
- **Automated** to receive, handle, polish and discharge product continuously
- **Self-contained**, auto-fed media system
- **Reduces labor**, operates without attendant
- **No mechanical wear parts**
- **Handles multiple products**, less than 5-minute changeover
- **Uses low-lint absorption media**, custom-made, FDA-compliant
- **Solid-state electromagnetic drive**, oil-free operation
- **Stand-alone or integration-capable**
- **Designed to meet FDA requirements**; complies with GAMP 4 guidelines
- **Exceptional service life / very low maintenance**

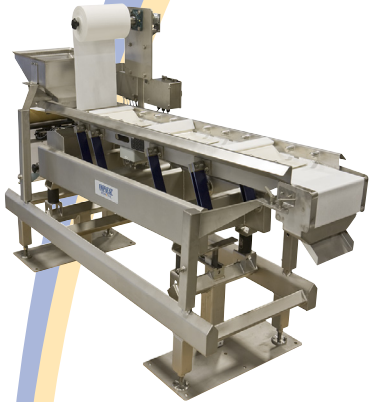

150 Avery Street, Walla Walla, Washington 99362-1668
+ 1-800-941-3701 • www.symetix.com

Pulse Scrubber®

Continuous Softgel Polishing Systems

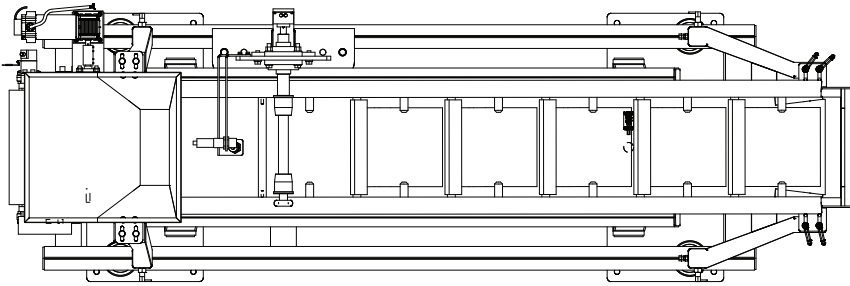

Dimensions

108" (2.7 meters) long

34" (.86 meters) wide

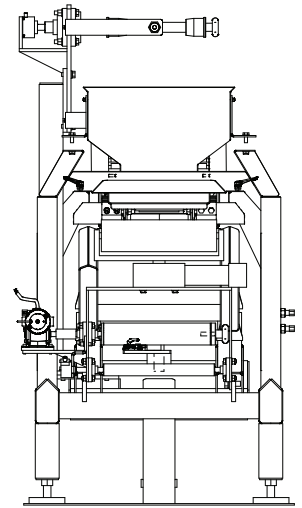
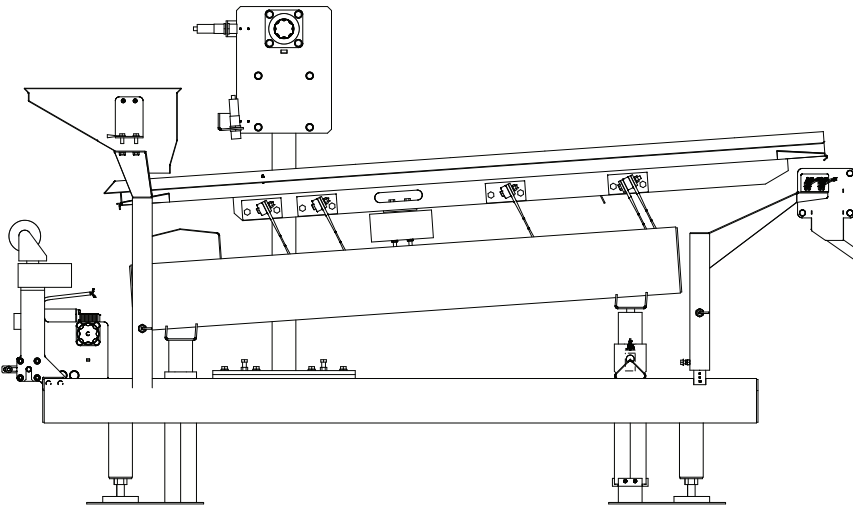

System capacity based on softgel size

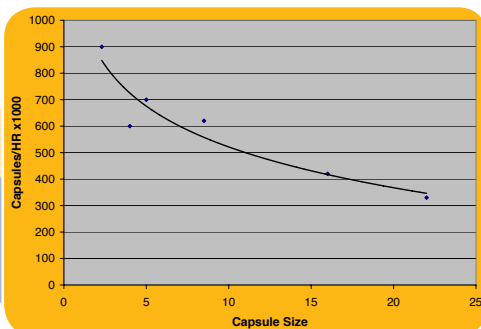

Utility requirements

Electrical: 10 Amps, 1 Phase

50/60 Hz, 200 - 230 VAC

Accompanying control panel to be wall-mounted near the PulseScrubber